

CODE NUMBER

3370400

DESCRIPTION

1.6/1.1 gpf, Polished Chrome Finish, Dual Flush, Battery, ECOS® Exposed Sensor Water Closet Flushometer.

DETAILS

- Flush Volume: 1.6/1.1 gpf (6.0/4.2 Lpf)
- Finish: Polished Chrome (CP)
- Power Type: Battery
- Battery Life: 6 years
- Valve: Diaphragm
- Valve Body Material: Semi-red Brass
- Fixture Type: Water Closet
- Fixture Connection: Top
- Rough-In Dimension: 11 ½" (292mm)
- Spud Coupling: 1 ½" (38mm)
- Supply Pipe: 1" (25mm)

FEATURES

- Handle Packing, Main Seat, Stop Seat and Vacuum Breaker Molded from PERMEX® Rubber Compound for Chloramine resistance
- User friendly three (3) second Flush Delay
- "Low Battery" Flashing LED
- Sweat solder adapter with cover tube and cast wall flange with set screw
- Fixed Metering Bypass and No External Volume Adjustment to Ensure Water Conservation
- If the user is present for less than one minute and leaves the sensing zone or chooses the small override button, a reduced flush initiates (1.1 gpf/4.2 Lpf) eliminating liquid and paper waste, saving 1/2 gallon of water
- If the user is present for greater than one minute and leaves the zone or chooses the large override button, the full flush initiates (1.6 gpf/ 6.0 Lpf) eliminating solid waste and paper
- Engineered Metal Cover with replaceable Lens Window
- PERMEX® Synthetic Rubber Flex Tube Diaphragm with Dual filtered bypass designed for improved life and reduced maintenance
- Four (4) Size AA alkaline Batteries included
- Courtesy Flush® Override Button
- 1" I.P.S. Screwdriver Bak-Chek® Angle Stop with Free Spinning Vandal Resistant Stop Cap
- PERMEX® Synthetic Rubber Diaphragm with Dual Filtered Fixed Bypass



COMPLIANCES & CERTIFICATIONS



(ADA Compliant, cUPC Certified, cUPC Green Certified, BAA Compliant, EPD, HPD)

RECOMMENDED SPECIFICATION

Valve Body, Cover, Tailpiece and Control Stop shall be in conformance with ASTM Alloy Classification for Semi- Red Brass. Valve shall be in compliance with the applicable sections of ASSE 1037 and ANSI/ASME 112.19.2.

ELECTRICAL SPECIFICATIONS

- Battery Life: 6 years

VALVE OPERATING PRESSURE (FLOWING)

15-80 PSI (103-552 kPa). Specific fixtures may require greater minimum flowing pressure - consult manufacturer requirements.

DOWNLOADS

- [Sloan ECOS Valve Installation Instructions](#)
- [Sloan Ecos Valve \(Spanish\) Installation Instructions](#)
- [Control Stop Repair and Maintenance Guide](#)
- [Flush Connections Flanges Repair and Maintenance Guide](#)
- [Tail Piece Repair and Maintenance Guide](#)
- [ECOS Repair and Maintenance Guide](#)
- [Additional Downloads](#)

NOTES

All information contained within this document subject to change without notice.

Looking for other variations of the ECOS 8111 product? [View the general spec sheet with all options.](#)

[Find a compatible urinal](#) for this flushometer.

[Find a compatible water closet](#) for this flushometer.

Sloan 10500 Seymour Ave, Franklin Park, IL 60131

Phone: 800.982.5839 • Fax: 800.447.8329 • sloan.com

ROUGH-IN

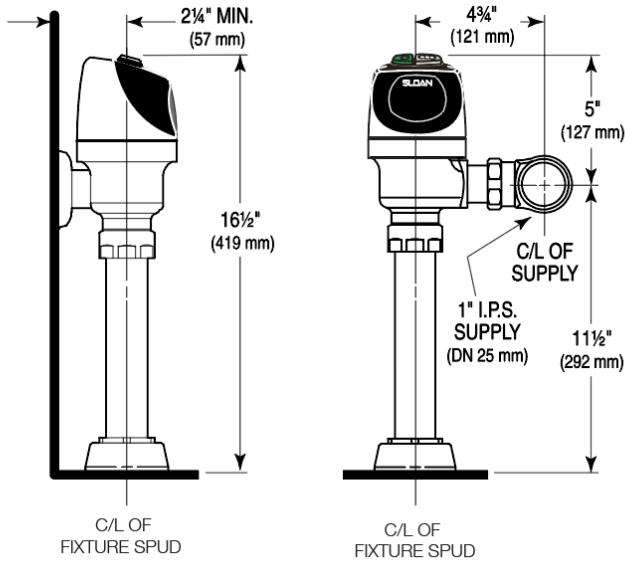

ALTERNATE ADA INSTALLATION

Lower water supply rough-in to 10" (254 mm) and mount grab bar at the 36" (914 mm) maximum allowed height (top of grab bar at 36").

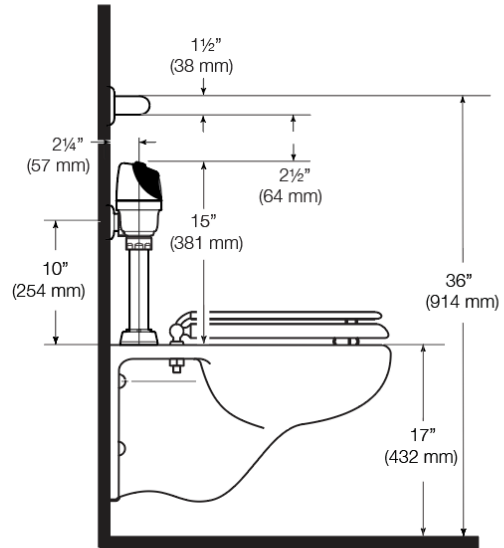

WHEN INSTALLING IN A HANDICAP STALL:

Per the ADA Guidelines (section 604.9.4) it is recommended that the grab bars be split or shifted to the wide side of the stall. If grab bars must be present over the valve, use the alternate ADA installation as shown to the right.

Sloan 10500 Seymour Ave, Franklin Park, IL 60131

Phone: 800.982.5839 • Fax: 800.447.8329 • sloan.com